

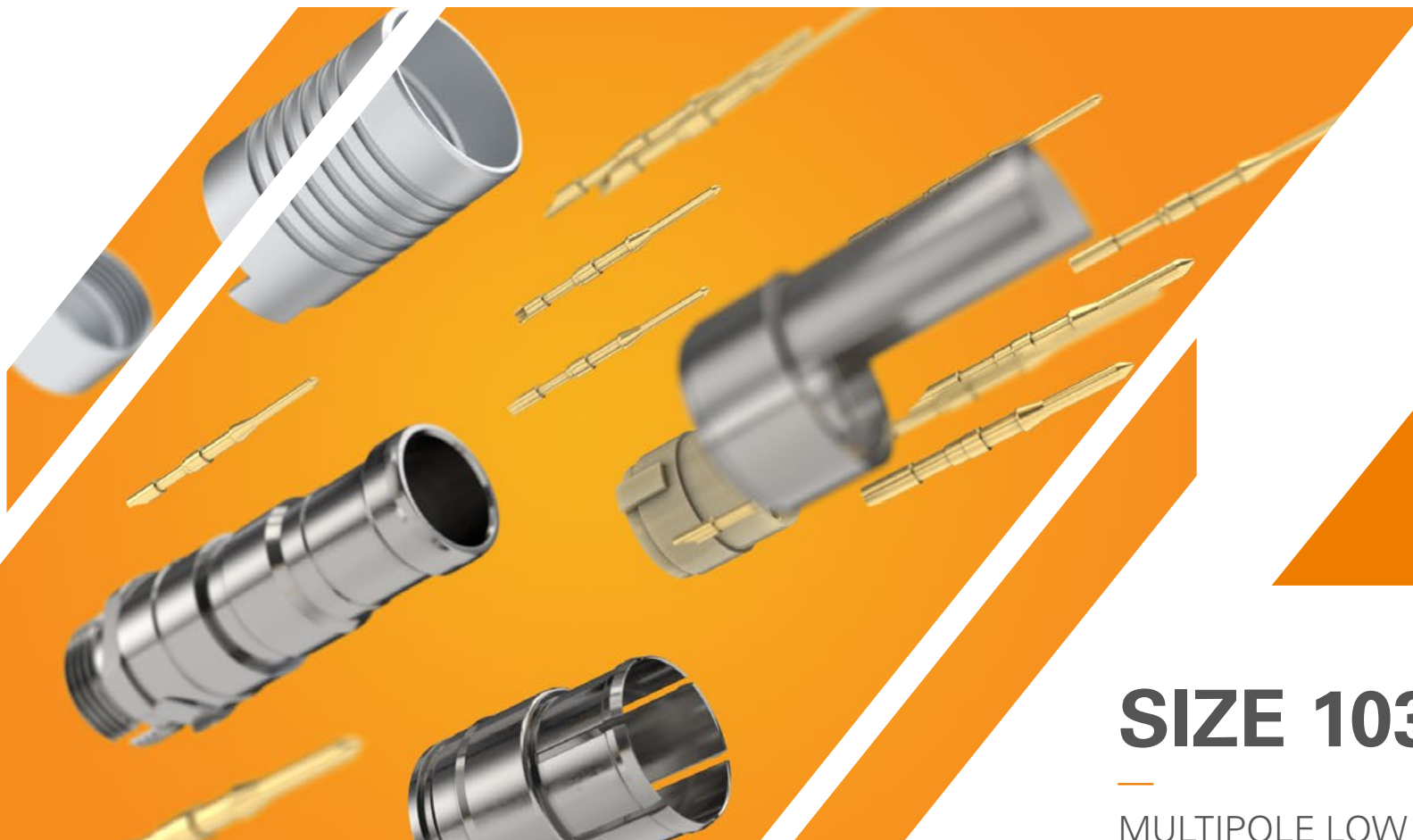

# FISCHER CORE SERIES

## CABLE ASSEMBLY INSTRUCTIONS



**SIZE 103**

MULTIPOLE LOW VOLTAGE

© Fischer Connectors SA – All rights reserved – Version 1.2 – 02.2024 – Changes without prior notice

**1** Remove shipping retainer and contact block

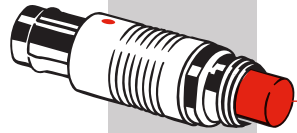

**2** Slide piece parts over cable (possibly with parts in plastic tube)

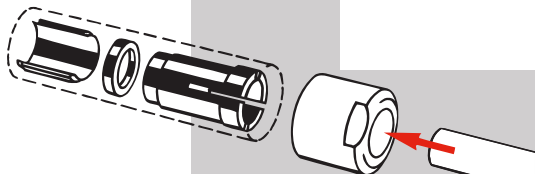

**S – UNSEALED & SHIELDED**

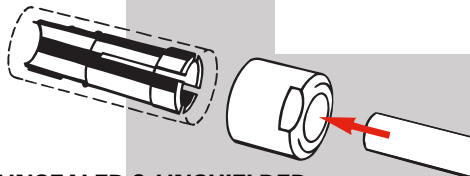

**U – UNSEALED & UNSHIELDED**

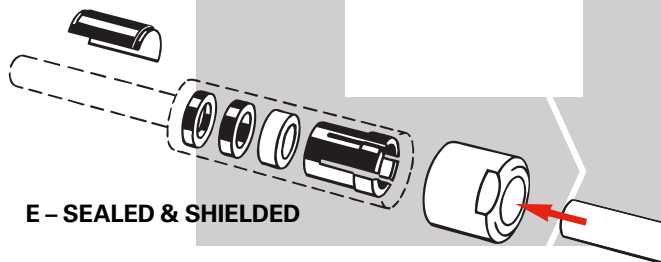

**E – SEALED & SHIELDED**

## CRIMP CONTACTS

**3** Strip cable and wires\*

**4** Fit wire into contact barrel and crimp\*

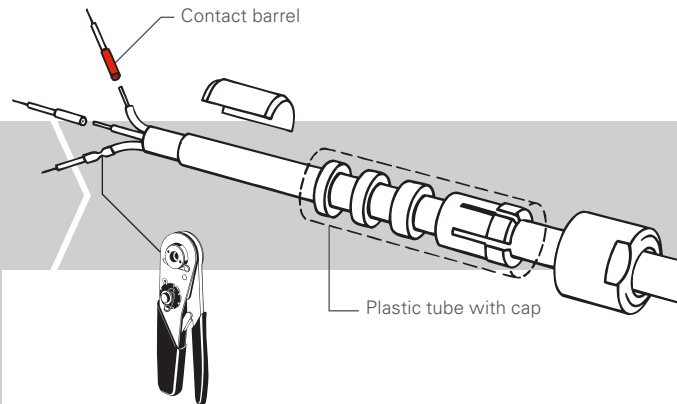

**5** Insert contacts into insulator and push them home with insertion tool\*

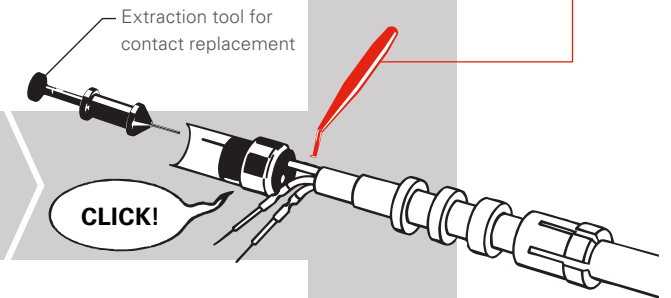

## SOLDER CONTACTS

**3'** Strip cable and wires\*

**4'** Tin strands (recommended)

**5'** Solder each wire to the corresponding contact\*, then pull heat shrinkable tubes over the contact terminals and shrink

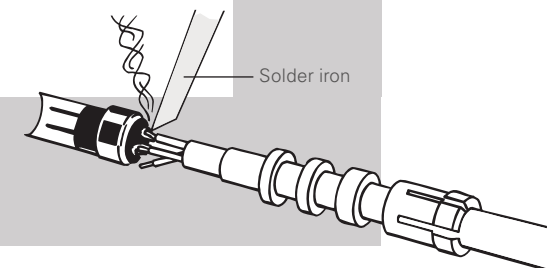
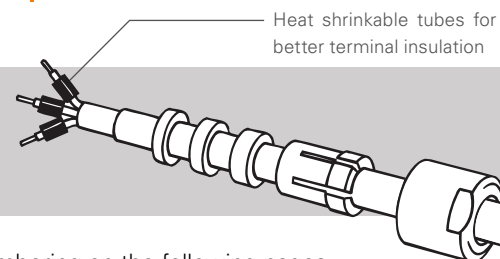

\*For ideal cable and wire preparation, see the specific tools and contact numbering on the following pages.

**6** | Slide **ring** towards front end

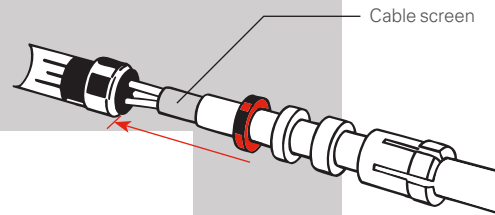

**7** | Bend  **cable screen**  outwards

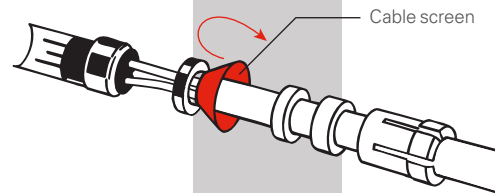

**8** | Insert  **half shell**  and retain with the ring

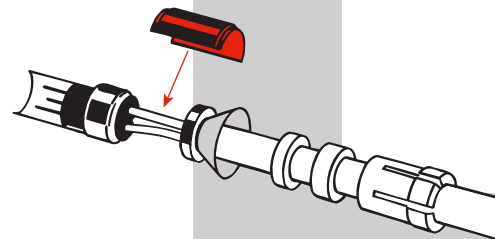

**11** | Push cable assembly into the body, orienting the  **guides**  to the slots

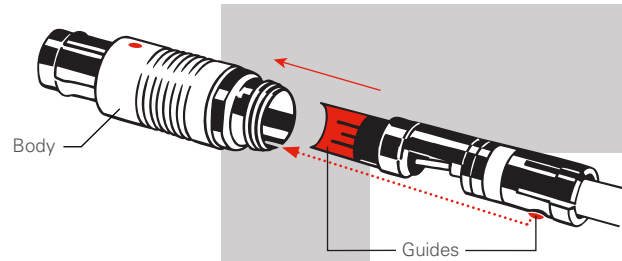

**10** | Trim protruding screen strands

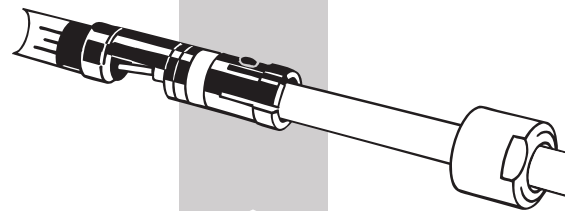

**9** | Slide  **washer, seal and clamp**  against the ring and retain screen between ring and washer

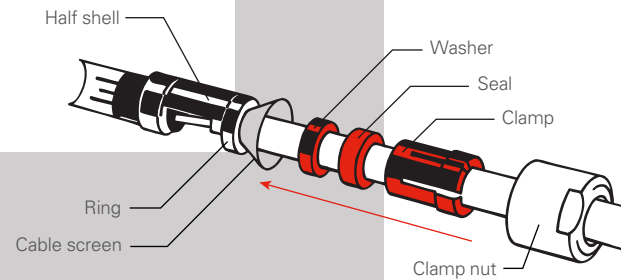

**12** | Screw  **clamp nut**  to body and tighten with wrenches\*

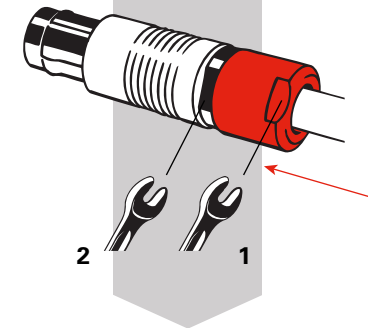











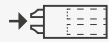
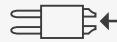
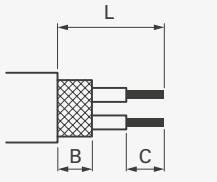

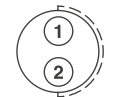
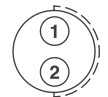
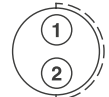
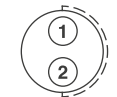

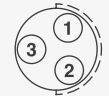
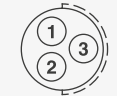
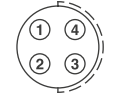
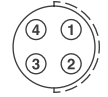
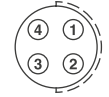
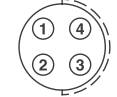
**The assembly is now complete.**

\*For ideal cable and wire preparation, see the specific tools and contact numbering on the following pages.

# SIZE 103

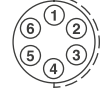
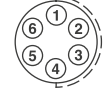
# MULTIPOLE LOW VOLTAGE CABLE ASSEMBLY INSTRUCTIONS

Type					Cable clamp <sup>1)</sup>	Contact termination	Number of contacts				Crimping tool part number	Positioner part number	Insertion tool part number	Extraction tool part number	Wrench size  1	Wrench size  2 <sup>2)</sup>	Torque [Nm]
	Plug	Receptacle	Plug	Receptacle				L	B	C							
	Type "A"		Type "Z"														
103 <sup>A</sup> / <sub>Z</sub> 051					S	Solder	2	8	2.5	2.5				10	10	1.0	
					U		2	8	-	2.5					10	10	1.0
					E		2	8	2	2.5					10	10	1.0
103 <sup>A</sup> / <sub>Z</sub> 052					S	Solder	3	8	2.5	2.5				10	10	1.0	
					U		3	8	-	2.5					10	10	1.0
					E		3	8	2	2.5					10	10	1.0
103 <sup>A</sup> / <sub>Z</sub> 053					S	Solder	4	8.5	2.5	2.5				10	10	1.0	
					U		4	9.5	-	2.5					10	10	1.0
					E		4	8.5	2	2.5					10	10	1.0
103 <sup>A</sup> / <sub>Z</sub> 054					S	Solder	5	8.5	2.5	2.5				10	10	1.0	
					U		5	9.5	-	2.5					10	10	1.0
					E		5	8.5	2	2.5					10	10	1.0
103 <sup>A</sup> / <sub>Z</sub> 056					S	Solder	6	8.5	2.5	2				10	10	1.0	
					U		6	8.5	-	2				10	10	1.0	
					E		6	9	2	2				10	10	1.0	
					S	Crimp	6	12.5	2.5	3	TX00.240	<sup>3)</sup>	TX00.210	TX00.200	10	10	1.0
					U		6	8.5	-	3	TX00.240	<sup>3)</sup>	TX00.210	TX00.200	10	10	1.0
					E		6	12.5	2	3	TX00.240	<sup>3)</sup>	TX00.210	TX00.200	10	10	1.0













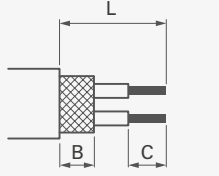



<sup>1)</sup> S - Shielded cable clamp  
 U - Unshielded cable clamp  
 E - Sealed cable clamp

<sup>2)</sup> Except for DK body style : Wrench size = 9

<sup>3)</sup> See Online Crimping Instructions

*All specifications are typical and have to be adjusted according to the cable construction and dimensions. Torque values [Nm] are recommended values that may be influenced by the characteristics of the cable jacket. Tests have to be made to evaluate the exact values. To secure the cable clamp nut, we recommend the use of thread locking adhesive.*

*All dimensions are in millimeters and are for reference only.*

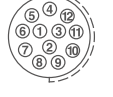
Type					Cable clamp <sup>1)</sup>	Contact termination	Number of contacts				Crimping tool part number	Positioner part number	Insertion tool part number	Extraction tool part number	Wrench size  1	Wrench size  2 <sup>2)</sup>	Torque [Nm]			
	Plug	Receptacle	Plug	Receptacle				L	B	C										
	Type "A"		Type "Z"																	
103 <sup>A</sup> / <sub>Z</sub> 057					S	Solder	7	6	8.5	2.5	2				10	10	1.0			
							1	6.5	2.5	2				10	10	1.0				
					U	Solder	7	6	9	-	2						10	10	1.0	
							1	7	-	2				10	10	1.0				
					E	Solder	7	6	9	2	2							10	10	1.0
							1	7	2	2				10	10	1.0				
S	Crimp	7	7	12.5	2.5	3	TX00.240	<sup>3)</sup>	TX00.210	TX00.200	10	10	1.0							
		U	7	9	-	3	TX00.240	<sup>3)</sup>	TX00.210	TX00.200	10	10	1.0							
		E	7	12.5	2	3	TX00.240	<sup>3)</sup>	TX00.210	TX00.200	10	10	1.0							
103 <sup>A</sup> / <sub>Z</sub> 058					S	Solder	8	7	8.5	2.5	2				10	10	1.0			
							1	6.5	2.5	2				10	10	1.0				
					U	Solder	8	7	9	-	2							10	10	1.0
							1	7	-	2				10	10	1.0				
					E	Solder	8	7	9	2	2							10	10	1.0
							1	7	2	2				10	10	1.0				
103 <sup>A</sup> / <sub>Z</sub> 062					S	Solder	12	9	8.5	2.5	2				10	10	1.0			
							3	6.5	2.5	2				10	10	1.0				
					U	Solder	12	9	9	-	2							10	10	1.0
							3	7	-	2				10	10	1.0				
					E	Solder	12	9	8.5	2	2							10	10	1.0
							3	6.5	2	2				10	10	1.0				

<sup>1)</sup> S - Shielded cable clamp  
 U - Unshielded cable clamp  
 E - Sealed cable clamp

<sup>2)</sup> Except for DK body style : Wrench size = 9

<sup>3)</sup> See Online Crimping Instructions

All specifications are typical and have to be adjusted according to the cable construction and dimensions. Torque values [Nm] are recommended values that may be influenced by the characteristics of the cable jacket. Tests have to be made to evaluate the exact values. To secure the cable clamp nut, we recommend the use of thread locking adhesive.

All dimensions are in millimeters and are for reference only.