

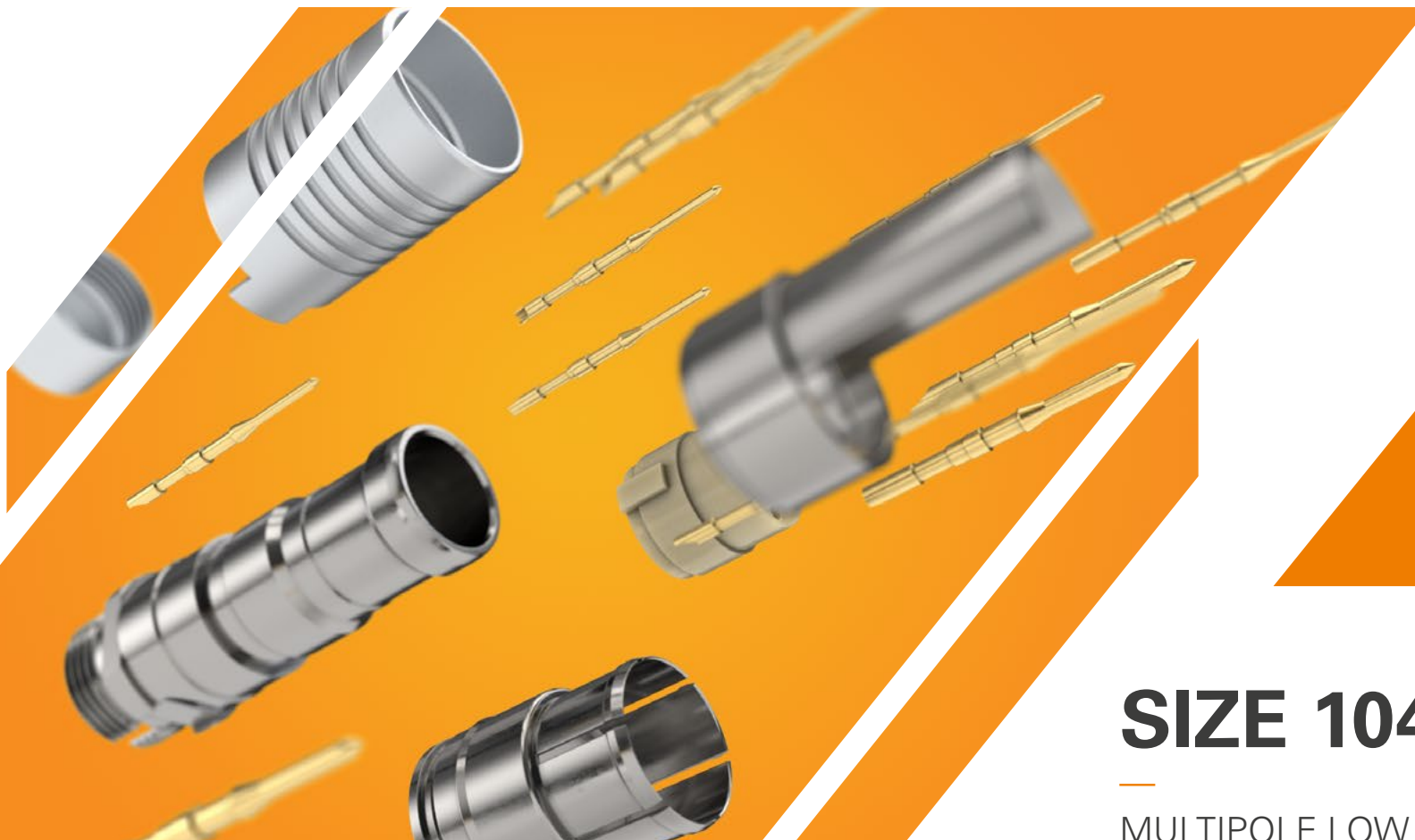

FISCHER CORE SERIES

CABLE ASSEMBLY INSTRUCTIONS



SIZE 104

MULTIPOLE LOW VOLTAGE

© Fischer Connectors SA – All rights reserved – Version 1.2 – 02.2024 – Changes without prior notice

1 Remove shipping retainer and contact block

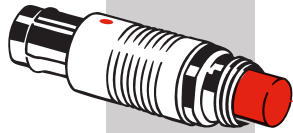

2 Slide piece parts over cable (possibly with parts in plastic tube)

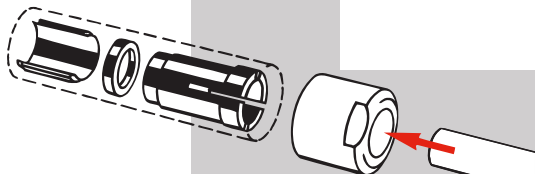

S – UNSEALED & SHIELDED

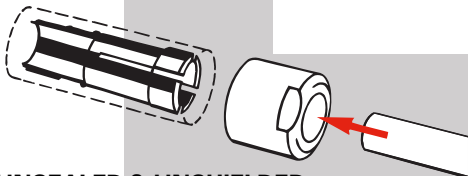

U – UNSEALED & UNSHIELDED

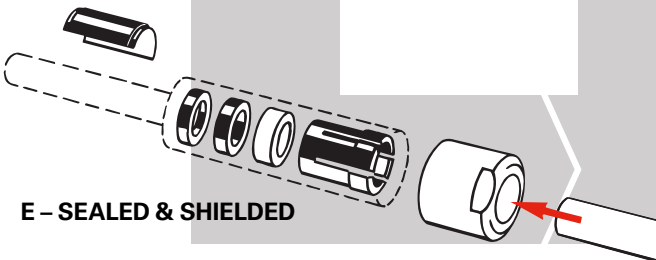

E – SEALED & SHIELDED

CRIMP CONTACTS

3 Strip cable and wires*

4 Fit wire into contact barrel and crimp*

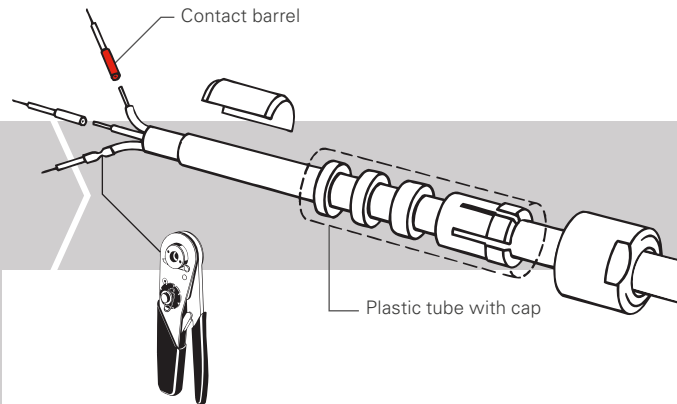

5 Insert contacts into insulator and push them home with insertion tool*

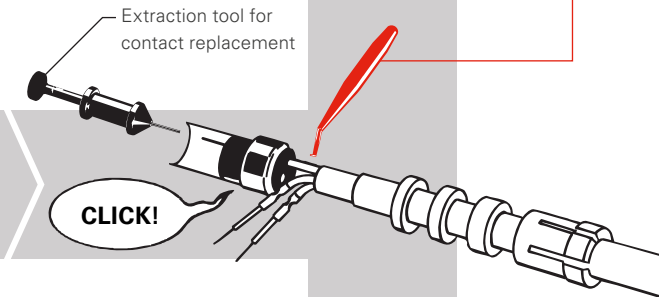

SOLDER CONTACTS

3' Strip cable and wires*

4' Tin strands (recommended)

5' Solder each wire to the corresponding contact*, then pull heat shrinkable tubes over the contact terminals and shrink

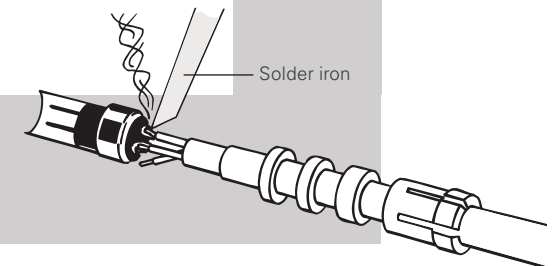
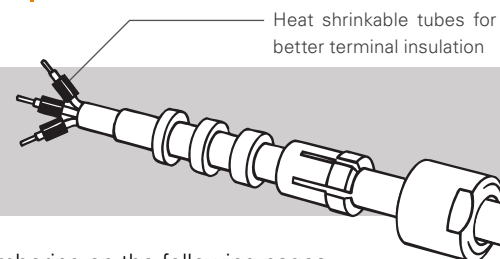

*For ideal cable and wire preparation, see the specific tools and contact numbering on the following pages.

6 | Slide **ring** towards front end

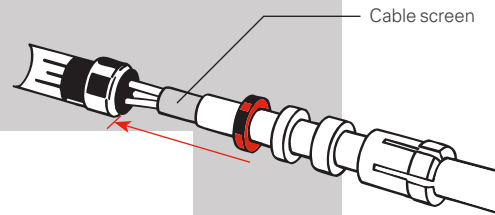

7 | Bend **cable screen** outwards

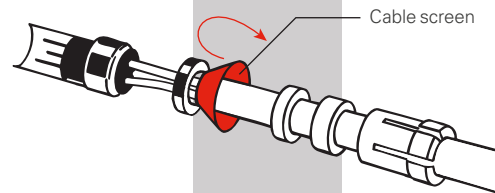

8 | Insert **half shell** and retain with the ring

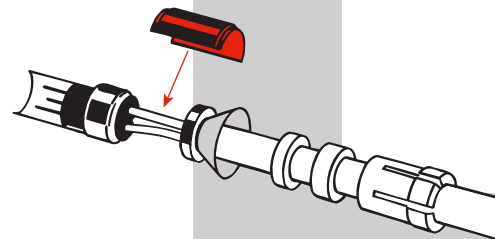

11 | Push cable assembly into the body, orienting the **guides** to the slots

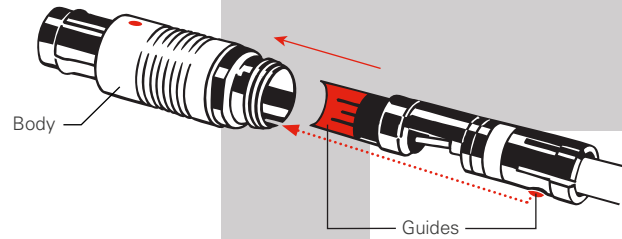

10 | Trim protruding screen strands

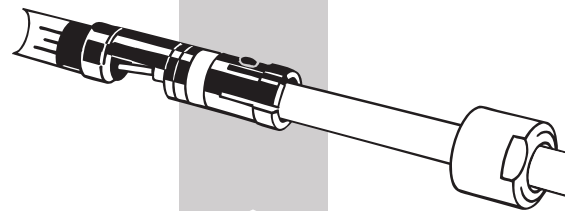

9 | Slide **washer, seal and clamp** against the ring and retain screen between ring and washer

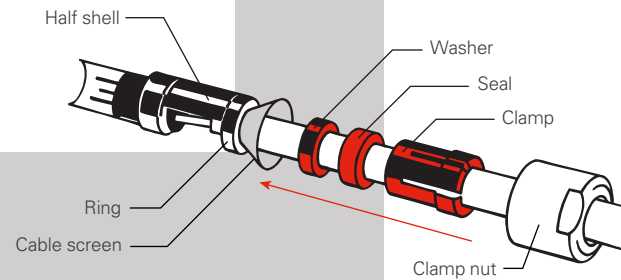

12 | Screw **clamp nut** to body and tighten with wrenches*

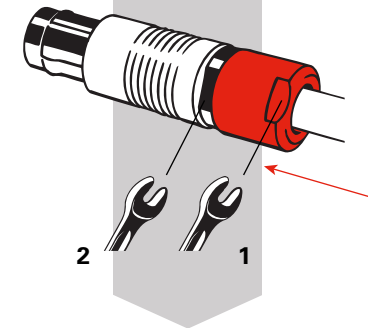





The assembly is now complete.

*For ideal cable and wire preparation, see the specific tools and contact numbering on the following pages.

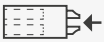
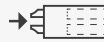
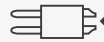
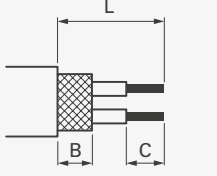
SIZE 104

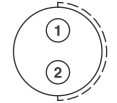
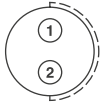
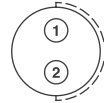
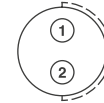
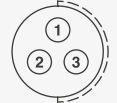
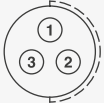
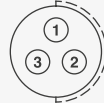
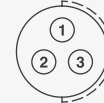
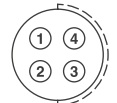
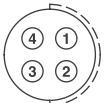
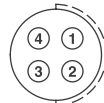
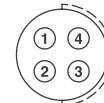
MULTIPOLE LOW VOLTAGE CABLE ASSEMBLY INSTRUCTIONS

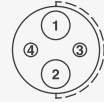
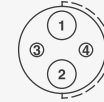
Type					Cable clamp ¹⁾	Contact termination	Number of contacts				Crimping tool part number	Positioner part number	Insertion tool part number	Extraction tool part number	Wrench size  1	Wrench size  2 ²⁾	Torque [Nm]
	Plug	Receptacle	Plug	Receptacle				L	B	C							
	Type "A"		Type "Z"														
104 ^A / _Z 051					S	Solder	2	11	2.5	3.5				12	13	2.0	
					U		2	11	-	3.5				12	13	2.0	
					E		2	11	2.5	3.5				12	13	2.0	
104 ^A / _Z 040					S	Solder	3	11	2.5	3.5				12	13	2.0	
					U		3	11	-	3.5				12	13	2.0	
					E		3	11	2.5	3.5				12	13	2.0	
					S	Crimp	3	12	2.5	5	TX00.242	³⁾		TX00.201	12	13	2.0
					U		3	12	-	5	TX00.242	³⁾		TX00.201	12	13	2.0
					E		3	12	2.5	5	TX00.242	³⁾		TX00.201	12	13	2.0
104 ^A / _Z 037					S	Solder	4	10	2.5	2.5				12	13	2.0	
					U		4	10	-	2.5				12	13	2.0	
					E		4	10	2.5	2.5				12	13	2.0	
104 ^A / _Z 087					S	Solder	4	2	9	2.5	2				12	13	2.0
					2			10	2.5	3.5				12	13	2.0	
					U		2	9	-	2				12	13	2.0	
							2	10	-	3.5				12	13	2.0	
					E		2	9	2.5	2				12	13	2.0	
							2	10	2.5	3.5				12	13	2.0	

¹⁾ S - Shielded cable clamp
 U - Unshielded cable clamp
 E - Sealed cable clamp

²⁾ Except for DK body style: wrench size = 12







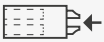
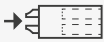

³⁾ See Online Crimping Instructions

All specifications are typical and have to be adjusted according to the cable construction and dimensions. Torque values [Nm] are recommended values that may be influenced by the characteristics of the cable jacket. Tests have to be made to evaluate the exact values. To secure the cable clamp nut, we recommend the use of thread locking adhesive.

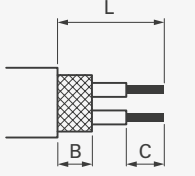
All dimensions are in millimeters and are for reference only.

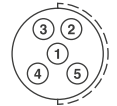
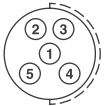
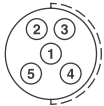
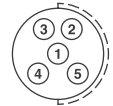
SIZE 104

MULTIPOLE LOW VOLTAGE CABLE ASSEMBLY INSTRUCTIONS

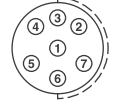
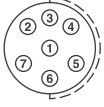
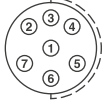
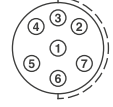
Type					Cable clamp ¹⁾	Contact termination	Number of contacts				Crimping tool part number	Positioner part number	Insertion tool part number	Extraction tool part number	Wrench size  1	Wrench size  2 ²⁾	Torque [Nm]	
	Plug	Receptacle	Plug	Receptacle				L	B	C								
	Type "A"		Type "Z"															
104 ^A / _Z 053					S	Solder	5	1	8	2.5	2.5				12	13	2.0	
								4	10	2.5	2.5				12	13	2.0	
					U		5	1	8	-	2.5				12	13	2.0	
								4	10	-	2.5				12	13	2.0	
					E		5	1	8	2.5	2.5				12	13	2.0	
								4	10	2.5	2.5				12	13	2.0	
104 ^A / _Z 065					S	Solder	6	1	10	2.5	2				12	13	2.0	
								U	6	10	-	2				12	13	2.0
								E	6	10	2.5	2				12	13	2.0
104 ^A / _Z 054					S	Solder	7	1	7	2.5	2				12	13	2.0	
								6	9	2.5	2				12	13	2.0	
					U		7	1	7	-	2				12	13	2.0	
								6	9	-	2				12	13	2.0	
					E		7	1	7	2.5	2				12	13	2.0	
								6	9	2.5	2				12	13	2.0	

¹⁾ S - Shielded cable clamp
 U - Unshielded cable clamp
 E - Sealed cable clamp









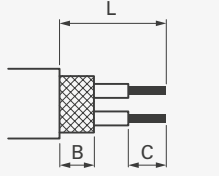

²⁾ Except for DK body style: wrench size = 12

All specifications are typical and have to be adjusted according to the cable construction and dimensions. Torque values [Nm] are recommended values that may be influenced by the characteristics of the cable jacket. Tests have to be made to evaluate the exact values. To secure the cable clamp nut, we recommend the use of thread locking adhesive.

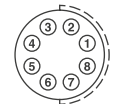
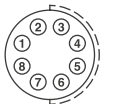
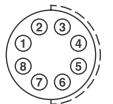
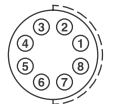
All dimensions are in millimeters and are for reference only.

SIZE 104

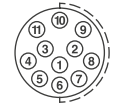
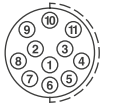
MULTIPOLE LOW VOLTAGE CABLE ASSEMBLY INSTRUCTIONS

Type					Cable clamp ¹⁾	Contact termination	Number of contacts				Crimping tool part number	Positioner part number	Insertion tool part number	Extraction tool part number	Wrench size  1	Wrench size  2 ²⁾	Torque [Nm]	
	Plug	Receptacle	Plug	Receptacle				L	B	C								
	Type "A"		Type "Z"															
104 ^A / _Z 066					S	Solder	8	9	2.5	2					12	13	2.0	
					U		8	9	-	2					12	13	2.0	
					E		8	9	2.5	2					12	13	2.0	
					S	Crimp	8	16	2.5	3.5	TX00.240	³⁾	TX00.211	TX00.205	12	13	2.0	
					U		8	16	-	3.5	TX00.240	³⁾	TX00.211	TX00.205	12	13	2.0	
					E		8	16	2.5	3.5	TX00.240	³⁾	TX00.211	TX00.205	12	13	2.0	
104 ^A / _Z 055					S	Solder	9	1	8.5	2.5	3				12	13	2.0	
					8			10.5	2.5	2					12	13	2.0	
					U		9	1	10	-	3					12	13	2.0
					E	9	8	12	-	2					12	13	2.0	
					S	9	1	8.5	2.5	3					12	13	2.0	
					8		10.5	2.5	2					12	13	2.0		
104 ^A / _Z 056					S	Solder	11	3	7	2.5	2				12	13	2.0	
					8			9	2.5	2					12	13	2.0	
					U		11	3	9	-	2					12	13	2.0
					E		11	8	11	-	2					12	13	2.0
					S	11	3	8.5	2.5	2					12	13	2.0	
					U		8	10.5	2.5	2					12	13	2.0	
					E		11	14.5	2.5	3	TX00.240	³⁾	TX00.211	TX00.205	12	13	2.0	
S	Crimp	11	12	-	3	TX00.240	³⁾	TX00.211	TX00.205	12	13	2.0						
U		11	14.5	2.5	3	TX00.240	³⁾	TX00.211	TX00.205	12	13	2.0						
E		11	14.5	2.5	3	TX00.240	³⁾	TX00.211	TX00.205	12	13	2.0						

¹⁾ S - Shielded cable clamp
 U - Unshielded cable clamp
 E - Sealed cable clamp

²⁾ Except for DK body style: wrench size = 12





³⁾ See Online Crimping Instructions

All specifications are typical and have to be adjusted according to the cable construction and dimensions. Torque values [Nm] are recommended values that may be influenced by the characteristics of the cable jacket. Tests have to be made to evaluate the exact values. To secure the cable clamp nut, we recommend the use of thread locking adhesive.

All dimensions are in millimeters and are for reference only.

SIZE 104

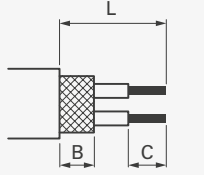
MULTIPOLE LOW VOLTAGE CABLE ASSEMBLY INSTRUCTIONS

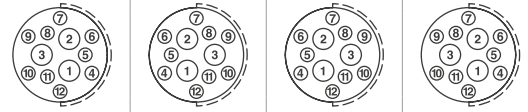
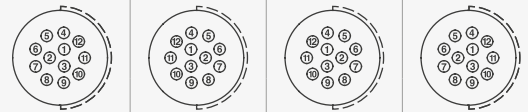
Type					Cable clamp ¹⁾	Contact termination	Number of contacts				Crimping tool part number	Positioner part number	Insertion tool part number	Extraction tool part number	Wrench size  1	Wrench size  2 ²⁾	Torque [Nm]
	Plug	Receptacle	Plug	Receptacle				L	B	C							
	Type "A"		Type "Z"														
104 ^A / _Z 104					S	Solder	12	3	8	2.5	2.5				12	13	2.0
								9	10.5	2.5	2				12	13	2.0
							12	3	8	-	2.5				12	13	2.0
								9	13	-	2				12	13	2.0
							12	3	8	2.5	2.5				12	13	2.0
								9	10.5	2.5	2				12	13	2.0
104 ^A / _Z 131					S	Solder	12	1 ³⁾	6	2.5	2				12	13	2.0
								2 ⁴⁾	5	2.5	2				12	13	2.0
								9 ⁵⁾	7.5	2.5	2				12	13	2.0
							12	1 ³⁾	8.5	-	2				12	13	2.0
								2 ⁴⁾	7.5	-	2				12	13	2.0
								9 ⁵⁾	10	-	2				12	13	2.0
							12	1 ³⁾	6	2.5	2				12	13	2.0
								2 ⁴⁾	5	2.5	2				12	13	2.0
								9 ⁵⁾	7.5	2.5	2				12	13	2.0

¹⁾ S - Shielded cable clamp
 U - Unshielded cable clamp
 E - Sealed cable clamp

³⁾ Pin number: 1
⁴⁾ Pin number: 2 to 3
⁵⁾ Pin number: 4 to 12







²⁾ Except for DK body style: wrench size = 12

All specifications are typical and have to be adjusted according to the cable construction and dimensions. Torque values [Nm] are recommended values that may be influenced by the characteristics of the cable jacket. Tests have to be made to evaluate the exact values. To secure the cable clamp nut, we recommend the use of thread locking adhesive.

All dimensions are in millimeters and are for reference only.

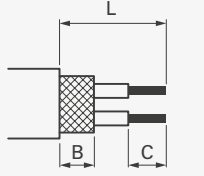
SIZE 104

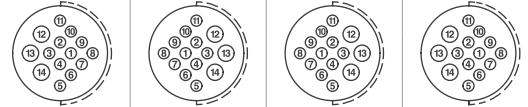
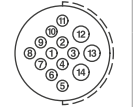
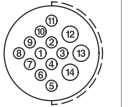
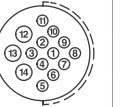
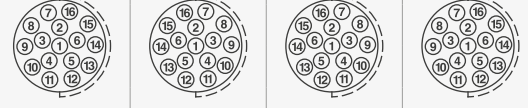
MULTIPOLE LOW VOLTAGE CABLE ASSEMBLY INSTRUCTIONS

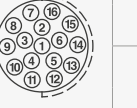
Type					Cable clamp ¹⁾	Contact termination	Number of contacts				Crimping tool part number	Positioner part number	Insertion tool part number	Extraction tool part number	Wrench size  1	Wrench size  2 ²⁾	Torque [Nm]	
	Plug	Receptacle	Plug	Receptacle				L	B	C								
	Type "A"		Type "Z"															
104 ^A / _Z 130					S	Solder	14	3 ⁴⁾	6	2.5	2					12	13	2.0
								1 ⁵⁾	5	2.5	2					12	13	2.0
								10 ⁶⁾	7.5	2.5	2					12	13	2.0
					U		14	3 ⁴⁾	8.5	-	2					12	13	2.0
								1 ⁵⁾	7.5	-	2					12	13	2.0
								10 ⁶⁾	10	-	2					12	13	2.0
					E		14	3 ⁴⁾	6	2.5	2					12	13	2.0
								1 ⁵⁾	5	2.5	2					12	13	2.0
								10 ⁶⁾	7.5	2.5	2					12	13	2.0
104 ^A / _Z 086					S	Solder	16	1	6.5	2.5	2					12	13	2.0
								5	8.5	2.5	2					12	13	2.0
								10	10.5	2.5	2					12	13	2.0
					U		16	1	9	-	2					12	13	2.0
								5	11	-	2					12	13	2.0
								10	13	-	2					12	13	2.0
					E		16	1	6.5	2.5	2					12	13	2.0
								5	8.5	2.5	2					12	13	2.0
								10	10.5	2.5	2					12	13	2.0
					S		Crimp	16	15.5	2.5	3	TX00.240	³⁾	TX00.210	TX00.200	12	13	2.0
					U			16	15.5	-	3	TX00.240	³⁾	TX00.210	TX00.200	12	13	2.0
					E			16	15.5	2.5	3	TX00.240	³⁾	TX00.210	TX00.200	12	13	2.0

¹⁾ S - Shielded cable clamp
¹⁾ U - Unshielded cable clamp
¹⁾ E - Sealed cable clamp

⁴⁾ Pin number: 2 to 4
⁵⁾ Pin number: 1
⁶⁾ Pin number: 5 to 14

²⁾ Except for DK body style: wrench size = 12





³⁾ See Online Crimping Instructions

All specifications are typical and have to be adjusted according to the cable construction and dimensions. Torque values [Nm] are recommended values that may be influenced by the characteristics of the cable jacket. Tests have to be made to evaluate the exact values. To secure the cable clamp nut, we recommend the use of thread locking adhesive.

All dimensions are in millimeters and are for reference only.

SIZE 104

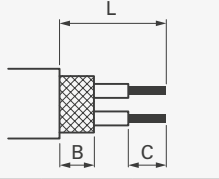
MULTIPOLE LOW VOLTAGE CABLE ASSEMBLY INSTRUCTIONS

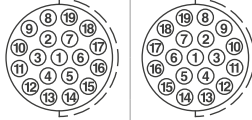
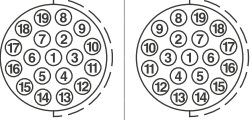
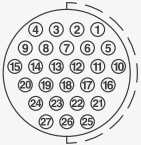
Type					Cable clamp ¹⁾	Contact termination	Number of contacts				Crimping tool part number	Positioner part number	Insertion tool part number	Extraction tool part number	Wrench size  1	Wrench size  2 ²⁾	Torque [Nm]
	Plug	Receptacle	Plug	Receptacle				L	B	C							
	Type "A"		Type "Z"														
104 ^A / _Z 092			S	Solder	19	1	6.5	2.5	2					12	13	2.0	
					19	6	8.5	2.5	2				12	13	2.0		
					19	12	10.5	2.5	2				12	13	2.0		
					19	1	9	-	2				12	13	2.0		
					19	6	11	-	2				12	13	2.0		
					19	12	13	-	2				12	13	2.0		
			19	1	6.5	2.5	2				12	13	2.0				
			19	6	8.5	2.5	2				12	13	2.0				
			19	12	10.5	2.5	2				12	13	2.0				
			19	15.5	2.5	3	TX00.240	³⁾	TX00.210	TX00.200	12	13	2.0				
			19	15.5	-	3	TX00.240	³⁾	TX00.210	TX00.200	12	13	2.0				
			19	15.5	2.5	3	TX00.240	³⁾	TX00.210	TX00.200	12	13	2.0				
104 A 124	Plug 		S	Crimp	27	14.5	2.5	2.5	TX00.240	³⁾	TX00.214	TX00.213	12	13	2.0		
			U		27	14.5	-	2.5	TX00.240	³⁾	TX00.214	TX00.213	12	13	2.0		
			E		27	14.5	2.5	2.5	TX00.240	³⁾	TX00.214	TX00.213	12	13	2.0		

¹⁾ S - Shielded cable clamp
 U - Unshielded cable clamp
 E - Sealed cable clamp

²⁾ Except for DK body style: wrench size = 12

³⁾ See Online Crimping Instructions

All specifications are typical and have to be adjusted according to the cable construction and dimensions. Torque values [Nm] are recommended values that may be influenced by the characteristics of the cable jacket. Tests have to be made to evaluate the exact values. To secure the cable clamp nut, we recommend the use of thread locking adhesive.

All dimensions are in millimeters and are for reference only.